

43AP PNEUMATIC INDICATING CONTROLLER Dimensional Print

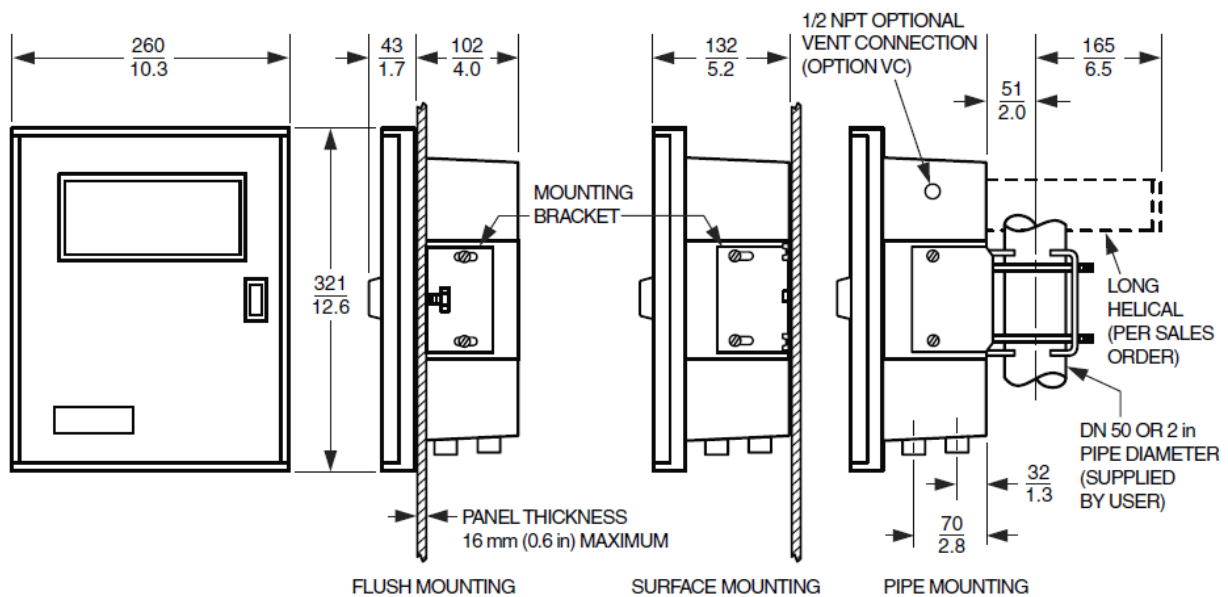

TEMPERATURE

RECEIVER 1/4 NPT FEMALE

RECEIVER Rc1/4 FEMALE

PRESSURE 1/4 NPT FEMALE

PRESSURE Rc1/4 FEMALE

PRESSURE 1/2 NPT MALE

PRESSURE R1/2 MALE

EXTERNAL RESET OR

REMOTE SET POINT

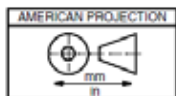
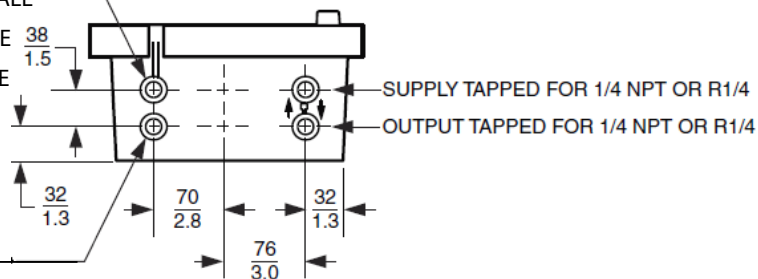

DP 011-476-AS

03.25.21

www.AutomationService.com

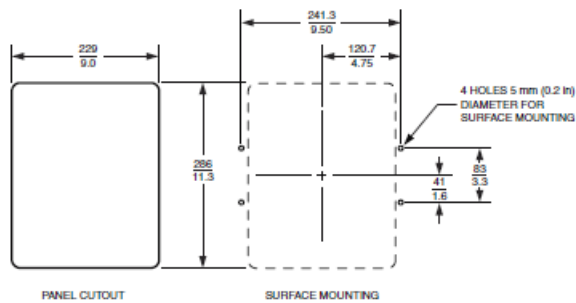
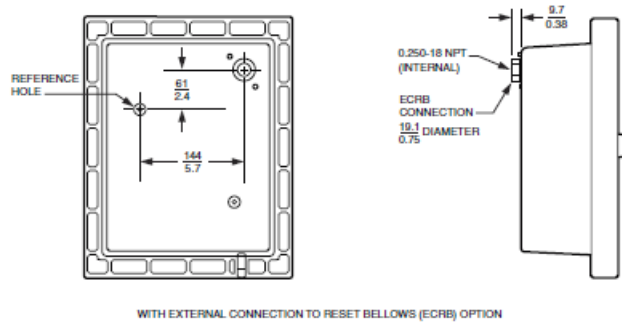
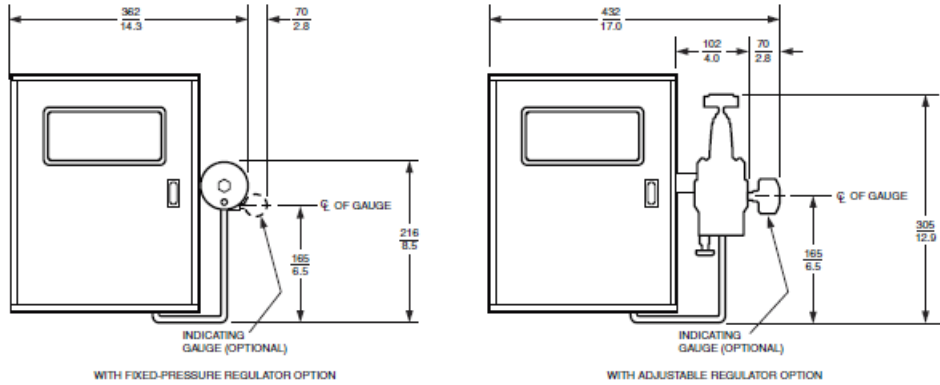

For horizontal multiple panel mounting, a minimum distance of 267 mm (10.5 in.) from center line to center line is required. For vertical multiple panel mounting, a minimum distance of 375 mm (14.8 in.) from center line to center line is required.

